

規格表 Specifications

型式 Type	相數 Phase	頻率 Frequency Hz	輸出功率 Power Kw	輸出電壓 Voltage V	滿載電流 Current A	最大靜壓 (吐出) Pressure (max) mmH ₂ O	最大風量 (吐出) Air Flow (max) m ³ /min	出口 口径 out Let (mm)	噪音 Noise level dB	重量 Weight Kgs
TB100-1	1φ 3φ	50/60	0.75	220 220/380	5 3/2.1	170/230	18/22	100	65/80	25
TB100-2	1φ 3φ	50/60	1.5	220 220/380	8 5.5/3.5	250/300	20/25	100	70/86	30
TB125-3	3φ	50/60	2.2	220/380	8/5	250/370	33/40	125	79/90	41
TB150-5	3φ	50/60	3.7	220/380	13/7.5	400/500	48/53	150	80/95	57
TB150-7.5	3φ	50/60	5.5	380	19	400/500	50/65	150	80/95	93
TB150-10	3φ	50/60	7.5	380	24	400/500	60/75	150	80/95	100
TB150L-7.5A	3φ	50/60	5.5	380	19	400/500	36/48	150	80/95	90
TB150L-10	3φ	50/60	7.5	380	24	520/650	40/53	150	86/108	108
TB200-15	3φ	50/60	11	380	36	520/650	70/90	200	87/105	185
TB200-20	3φ	50/60	15	380	47	550/700	90/100	200	88/110	188

性能曲綫 Performance curve

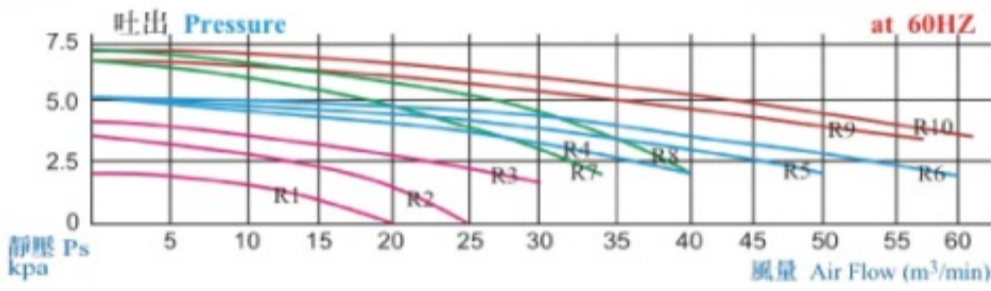
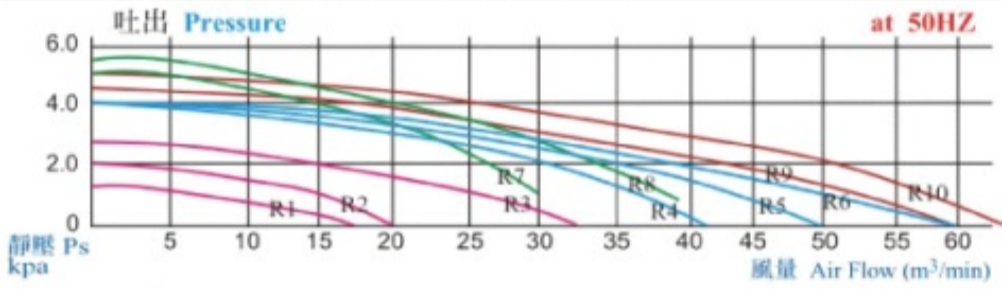

尺寸圖 Dimensions

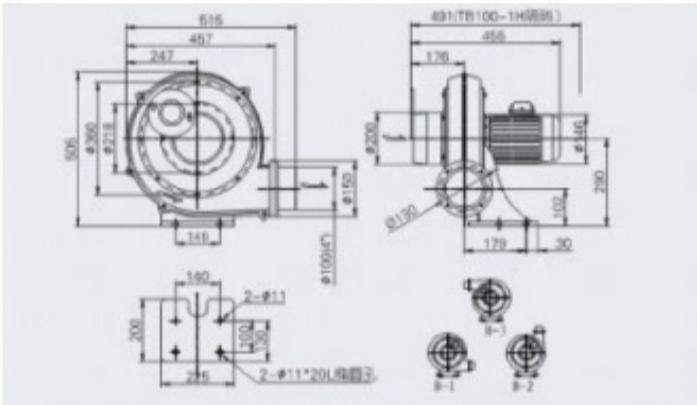

TB100-1

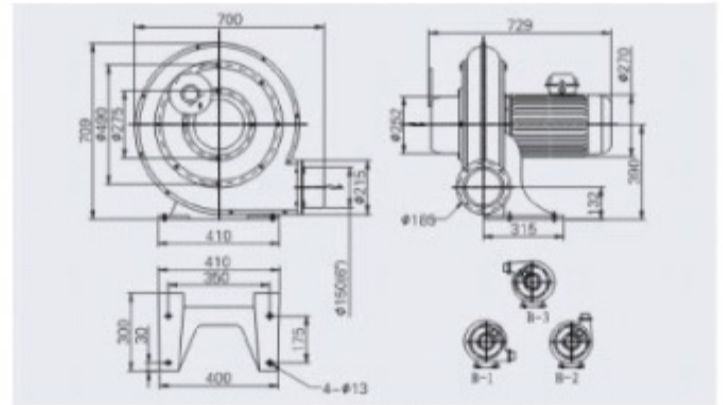

TB150-7.5/TB150-10

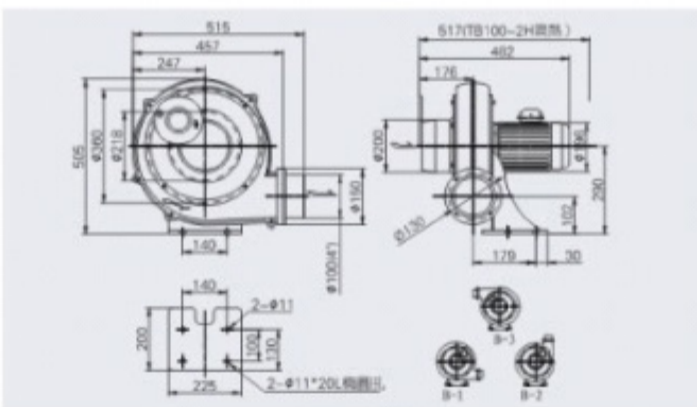

TB100-2

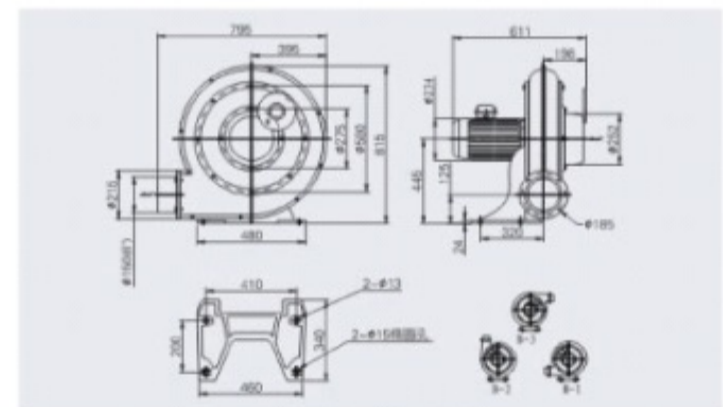

TB150L-7.5A

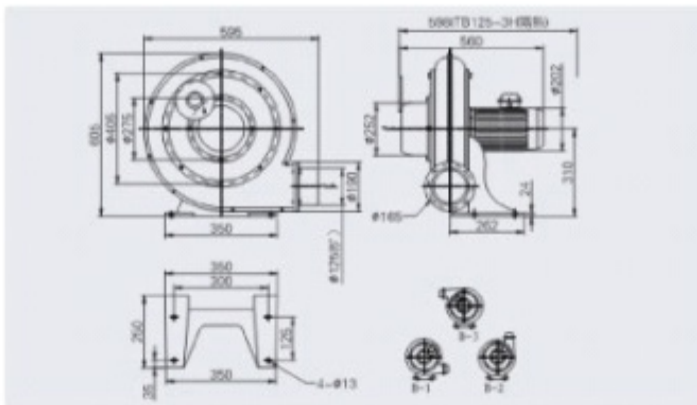

TB125-3

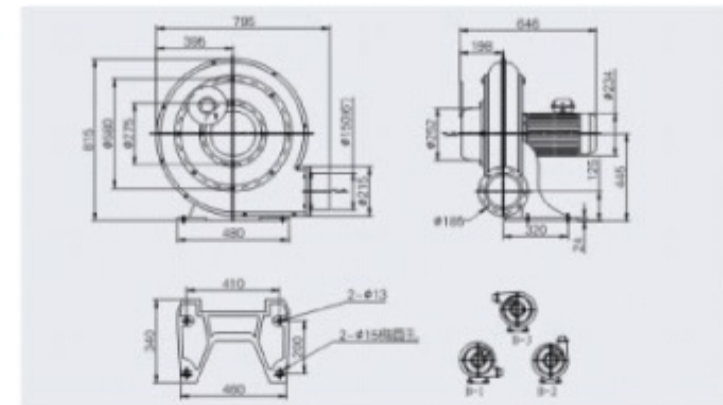

TB150L-10

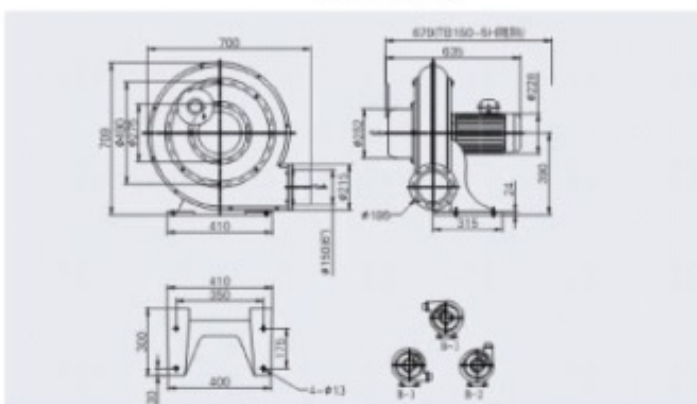

TB150-5

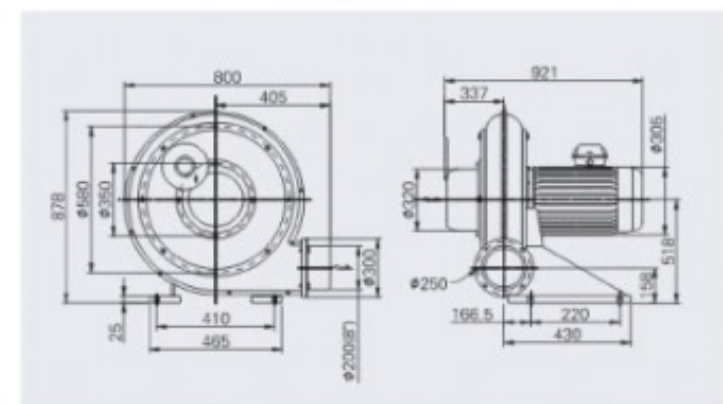

TB200-15 / TB200-20